

## RESOLUTION NO. 2026-15

### A RESOLUTION OF THE CITY COUNCIL OF THE CITY OF UKIAH ADOPTING GATEWAY LOCATIONS AND AFFIRMING THE DESIGN AND DEVELOPMENT STANDARDS CONSISTENT WITH GENERAL PLAN POLICY LU-11.2

#### WHEREAS:

1. The City of Ukiah 2040 General Plan established Policy LU-11.2 and Implementation Program D, which direct the City to identify and enhance gateways through landscape design, signage, building form, and historic themes; and
2. Prior City and County planning documents, including the City of Ukiah 1995 General Plan and Growth Management Program and County of Mendocino Ukiah Valley Area Plan (UVAP), and subsequent public infrastructure investments have established gateway-related design principles through coordinated public improvements; and
3. Staff have evaluated gateway concepts over time through previously adopted plans, prior studies, and realized public improvements, and have determined that many of the City's previous gateway objectives have been advanced through previous planning documents public investments, such as the Department of Public Works State Street Streetscape Phases 1 & 2, as well as the Urban Core Rehabilitation Program; and
4. The Planning Commission, at its January 28, 2026 meeting, reviewed the proposed gateway policies and locations and provided recommendations, including incorporation of light pole banner standards and local artist involvement; and
5. The Planning Commission's recommendations included the incorporation of semi-permanent or seasonal light pole banners along gateway corridors such as Perkins Street, and in response, Staff recommends utilizing the existing City of Ukiah Light Pole Banner standards, attached hereto as Exhibit B; and
6. It is the intent of the City Council that the formalized gateway locations and standards provide direct, adopted guidance for all future public improvement projects within the identified corridors, including those coordinated with Caltrans and upcoming City Public Works initiatives; and
7. The City's streetscape and corridor improvement projects demonstrate that gateway character can be effectively established through public infrastructure and design consistency, without imposing new development regulations or additional requirements on private parcels; and
8. The identification of gateway locations is intended to distinguish specific points or zones of arrival from broader corridor planning efforts, and to provide guidance for the placement and design of gateway features identified in Exhibit A, rather than to regulate surrounding land uses; and
9. Future public or private projects located in the immediate vicinity of identified gateways should avoid features that would interfere with, obscure, or visually compete with established or planned gateway signage and design elements; and

10. The Planning Commission, at its March 11, 2026, meeting, adopted Resolution No. PC 2026-02, recommending that the City Council adopt the gateway locations and affirm the design and development standards.

**NOW, THEREFORE, BE IT RESOLVED** that the City Council of the City of Ukiah hereby:

1. Directs that first-level regional gateways and proposed second-level City gateways, as identified in Exhibit A to this Resolution, be incorporated into final placement, design, and gateway features subject to site conditions, funding, project cost, infrastructure constraints, safety considerations, and coordination with future capital improvement projects; and
2. Affirms the use of existing Public Works standards, adopted plans, and previously constructed public improvements to implement General Plan Policy LU-11.2 and Implementation Program D inform the selection, construction, maintenance, upgrades and improvements to the Perkins Street, Gobbi Street and Talmage Road corridors and gateways; and
3. Directs that future public and private projects located in the vicinity of identified second level gateways avoid features that would interfere with, obscure, or visually compete with established gateway signage and design elements; and
4. Directs the Community Development Director to analyze and produce recommendations to the City Council for removal of, or improvements to, older publicly sponsored gateway signage; and
5. Directs Staff to research potential funding sources for second-level gateways as identified and referenced in Exhibit A; and
6. Approve and incorporate the City of Ukiah Light Pole Banner standards, attached hereto as Exhibit B, to be utilized along designated gateway corridors; and
7. Directs Staff to apply these adopted gateway standards to future public infrastructure and improvement projects, including coordination with Caltrans and Public Works initiatives; and
8. Directs Staff to award preference points for local artists during the procurement process in any future design and conceptualization phases of future City-sponsored gateway installations.

**PASSED AND ADOPTED** this 1st day of April, 2026, by the following vote:

AYES: Councilmembers Rodin, Criss, and Mayor Sher.  
NOES: None.  
ABSTAIN: None.  
ABSENT: Councilmembers Crane and Orozco.

  
\_\_\_\_\_  
Susan Sher, Mayor

ATTEST:  
  
\_\_\_\_\_  
Araceli Sandoval, Deputy City Clerk



APN 169-211-07 Unincorporated Mendocino County

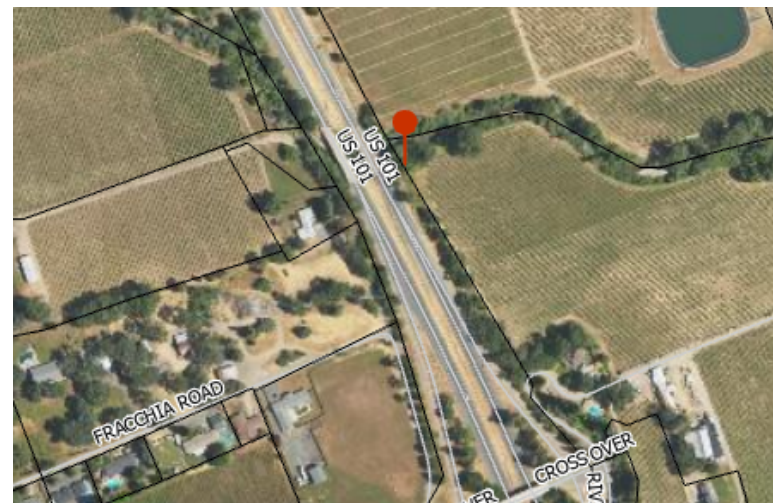

APN 184-210-03 Unincorporated Mendocino County

# UKIAH GATEWAY STANDARDS AND DESIGNATED LOCATIONS - REFERENCE LOCATIONS (SECOND LEVEL)

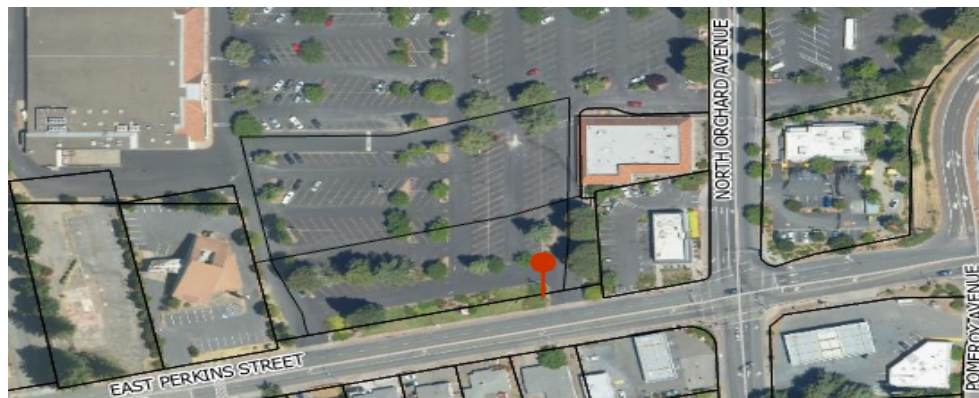

Perkins Street

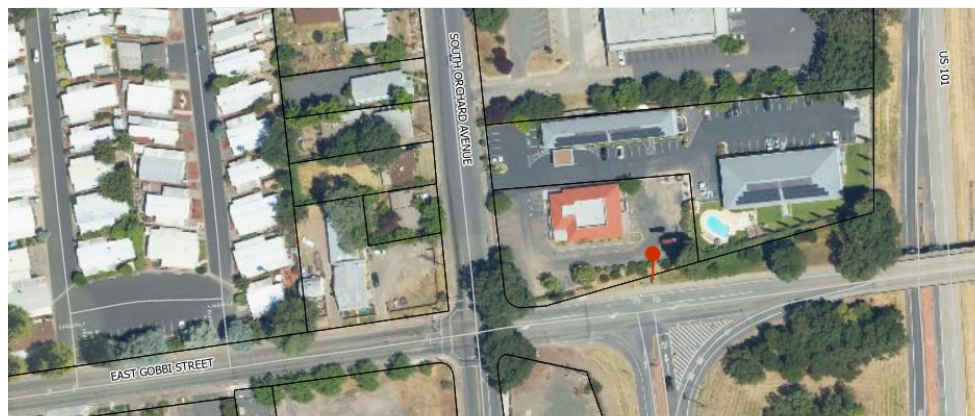

Gobbi Street



Talmage Road

Concept 01

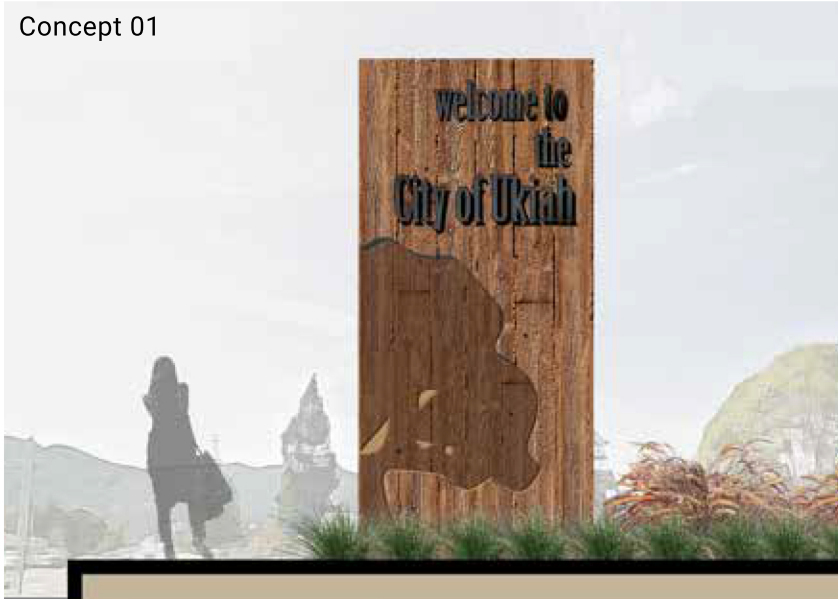

Concept 03



Concept 02

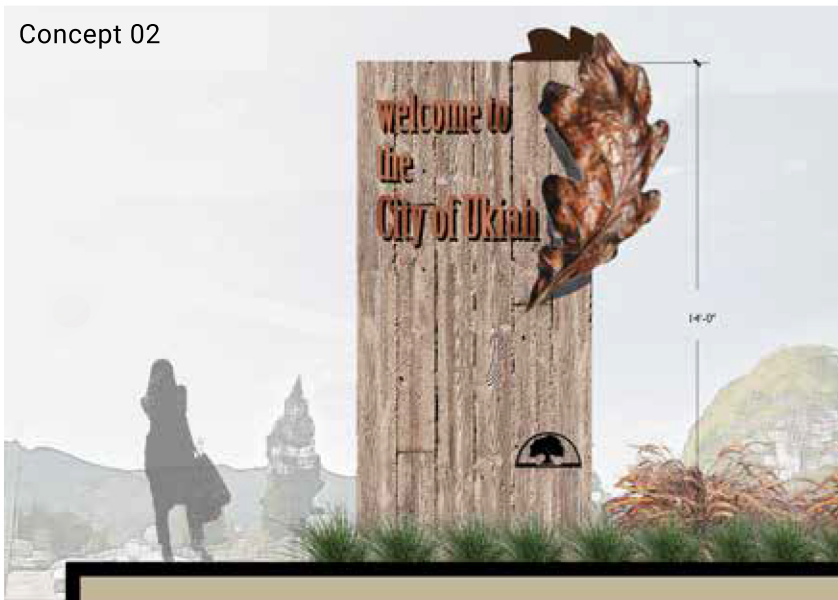

Concept 04



TREES— Downtown Core



Historic Downtown Street Tree  
*Platanus x acerifolia*, London Plane

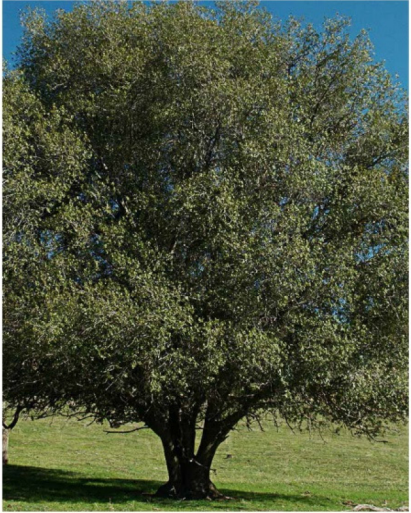

Special Corner Street Tree  
*Quercus wislizeni*, Interior Live Oak



Perkins Street Tree  
*Acer rubrum*, Red Maple



Standley Street Tree  
*Ulmus parvifolia*, Chinese Elm

TREES— South of Clay



Small Street Tree  
*Aesculus x carnea*,  
Red Horse Chestnut



Small Street Tree  
*Koelreuteria paniculata*,  
Golden Rain Tree



Small Street Tree  
*x Chitalpa tashkentensis*  
'Pink Dawn'

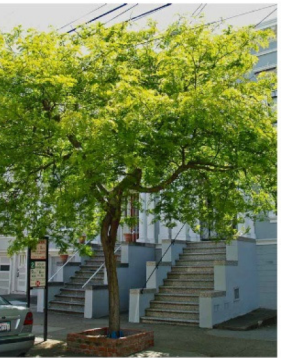

Small Street Tree  
*Robinia x ambigua*,  
Purple Robe Locust

Landscape Architecture Tree Lists, State Street Streetscape Phase 1 (2019)

SHRUBS & GROUND COVER



*Achillea millefolium* 'Paprika'



*Lomandra longifolia* 'Breeze'



*Eriophyllum confertiflorum*, Yarrow



*Calamagrostis x acutiflora*  
'Overdam'



*Ceanothus* 'Dark Star'



*Iris douglasiana*



*Erigeron karvinskianus* 'Profusion'



*Gladiolus communis* subsp.  
*byzantinus*



*Santolina chamaecyparissus*

Landscape Architecture Softscape Elements, State Street Streetscape Phase 1 (2019)

HARDSCAPE, FURNISHINGS, & LIGHTING

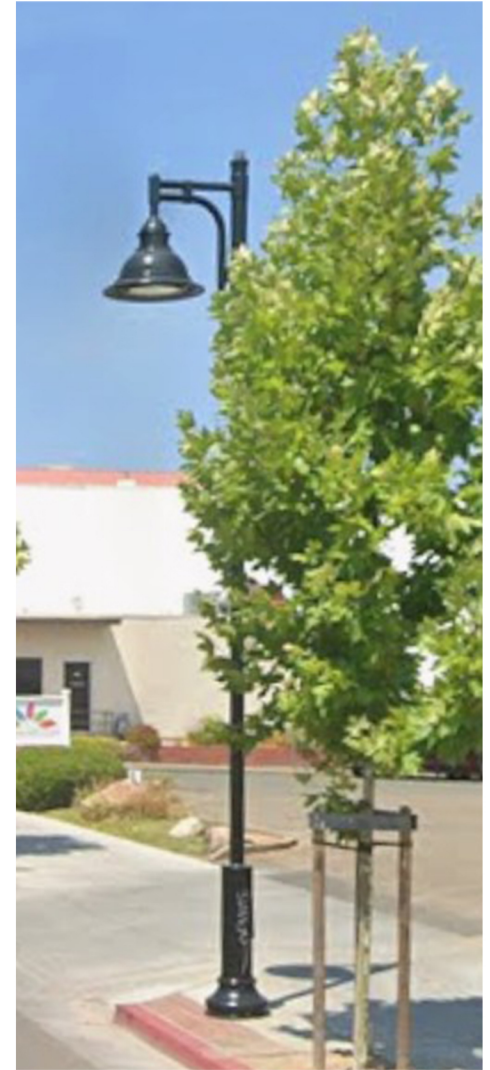

Landscape Architecture Hardscape Elements, State Street Streetscape Phase 1 (2019)

## CITY OF UKIAH LIGHT POLE BANNER POLICY

**TITLE:** DISPLAY OF BANNERS ON STREET LIGHT POLES FOR COMMUNITY EVENTS, AWARENESS PURPOSES, EDUCATION, HEALTHCARE AFFILIATES AND NON-PROFIT ORGANIZATIONS

**PURPOSE:** The City of Ukiah Light Pole Banner Program is intended to increase awareness of Ukiah-area events, activities and organizations, as well as add color and excitement to the City's streetscapes.

The City of Ukiah's Community Services Department manages and processes permits for the installation of banners on City-owned street light poles.

**DESCRIPTION:** The City of Ukiah will install and remove banners for approved Community Events and Awareness Initiatives on the City-owned street light poles, on a first-come, first-served basis. Banners are to be provided by and maintained by the event/initiative organizer and/or chairperson. Banners will be installed by the City on or about the first day of the month 30 days preceding the scheduled event (e.g. if an event is scheduled for March 1st, a banner can be installed on or about February 1st.) Banners will be removed by the City on or about the first day of the month following the Community Event or Awareness Initiative.

**LOCATIONS:** There are 12 poles located on State Street between Clay Street and Henry Street; 9 poles on East Perkins Street between State Street and Orchard Avenue; and 5 (double-banner) poles on Airport Park Boulevard.

**PARTICIPATION:** Participation and placement of banners is limited to, Community Organizations, Educational Institutions or Governmental Bodies, Community Events and Awareness Initiatives that have been recognized and approved by the City of Ukiah to be held in the City of Ukiah. Banners may not include typical advertisement themes (such as but not limited to, "Sale", "Open for Business", "Grand Opening", etc.), or political or religious messages.

**DESIGN OF BANNERS:** Banners should be designed to reflect the unique nature of each Community Event or Awareness Initiative and to promote the purpose and benefits to the community. The design and text of the banner cannot include any corporate advertisements. The City encourages unique designs and bright colors that can add to the overall appearance of the downtown area. Banners should be designed so that the imagery and type are appropriately scaled for long-range visibility. Text should be limited and not include prices, telephone numbers, and addresses. The City of Ukiah's Community Services staff shall have the right of final approval for the design of any banner to be installed under this policy.

**Specifications:** The banner size must meet the following specifications.

- Banners must be 24 inches in width and 72 inches in length (24" x 72") "Exhibit D"
- 4" rod pocket is required at the top and bottom of the banner
- Grommets should be placed 1" below and above the casing line. Both grommets should be 1" from the edge
- Banners should be made from 15 oz. rip-stop vinyl or equivalent material
- All rod pockets sewn with cotton thread and double lock stitch seams
- Banners are to be double-sided and identical on both sides
- The applicant is responsible for banner fabrication

- Any variations to these guidelines must be approved by the Community Services Staff.

***If there are any questions, please contact the Community Services Department at (707) 463-6231 PRIOR to ordering banners.***

**PLACEMENT:** The City has approximately 26 light poles on which banners can be installed. The City reserves the right to limit the number of banners used for any Community Event or Awareness Initiative. The minimum number of banners that can be displayed is six poles on State Street and/or five poles on East Perkins Street. If the Airport Park Boulevard location is selected, all five poles must be used. The City reserves the right to adjust the actual location site if other banners are currently installed. Anyone requesting installation at a specific location(s) should indicate both a first choice and a second choice for placement of their banner(s). The City of Ukiah cannot be responsible for delays in installation or damage due to vandalism, theft or loss, weather conditions or disaster events.

**FEES:** The fee for use of the City poles is \$30 per pole for installation and removal of the banners. Applicants are responsible for all costs related to the design, production, and delivery. Applicants are responsible for maintenance and storage of the banners prior to and after installation. Banners will be displayed for four weeks prior to the event or for 30 days during specific Awareness Initiatives. Additional weeks may be requested, depending on availability. All fees must be paid in full to the City of Ukiah 14 days prior to installation.

**REQUEST FOR PARTICIPATION:** Request for participation in this program shall be submitted to the Community Services Department. Request must be submitted using the attached form/application along with one copy (hard copy or e-mail) of the banner design. They can be mailed or emailed to the Community Services Department. Design revisions and re-submission may be required.

All applications for the banner program will be considered in the following priority:

1. City of Ukiah sponsored events, activities, or programs
2. Existing events, activities, or programs with previously approved applications
3. New events, activities, or programs offered by community organizations or governmental bodies

**APPLICATION TIME LINE:**

- One-year maximum and two months minimum prior to event or initiative date, application and banner design proposal must be submitted to the Community Services Department at 411 West Clay Street, Ukiah or emailed to [recreation@cityofukiah.com](mailto:recreation@cityofukiah.com).
- Community Services staff will review the application.
- Within 30 days following the submission of application and design, the Community Services Staff will contact the applicant with approval, rejection, or amendments to the application.
- If the Banner Use Application is approved, a Banner Use Agreement, Exhibit "C" will be issued.
- 14 days prior to banners being installed, fees are to be paid in order to reserve the banner space. Fees are non-refundable and non-transferable in the event the applicant cancels the banner request.
- Banner are to be delivered to Community Services 14 days before the installation date.
- Banners will be installed by City Staff on or about the first day of the month 30 days preceding the scheduled event.
- Banners are taken down by City staff and delivered back to Community Services Department.

- Pick-up and storage of banners after removal is required by the applicant. No banners will be stored at the Community Services Department longer than ten business days.

**PRIOR APPROVAL FOR THE DESIGN AND INSTALLATION OF BANNER IS REQUIRED FROM THE CITY OF UKIAH. PLEASE DO NOT ORDER ANY BANNERS WITHOUT FIRST OBTAINING CITY APPROVAL.**

I have read and understand all aspects of this program including but not limited to: use, design, technical requirements, cost and conditions as outlined. I understand this application may be approved or denied based upon the program guidelines, banner space available and/or agreements with the City of Ukiah.

Applicant Signature \_\_\_\_\_ Date \_\_\_\_\_

**Please submit this application with the appropriate deposit check payable to City of Ukiah, and mail to:**

City of Ukiah  
411 W. Clay Street  
Ukiah, CA 95482

**Exhibit "C"**

**CITY OF UKIAH  
DOWNTOWN BANNER PROGRAM USE AGREEMENT**

THIS AGREEMENT is entered this \_\_\_\_\_ day of \_\_\_\_\_ 20\_\_\_\_ between  
City of Ukiah, 411 West Clay Street, Ukiah CA 95482 and \_\_\_\_\_  
(hereinafter referred to as "Banner User"), (address),  
\_\_\_\_\_  
\_\_\_\_\_

1. Banner User hereby agrees that City of Ukiah, in its handling, transporting, installation or use of Banner User's banners, makes no warranty or guarantee with respect to the care, custody, safekeeping, good condition, or timely installation of such banners. And City of Ukiah hereby disclaims all responsibility for loss or damage to such banners, whether resulting directly, consequentially, or incidentally from City of Ukiah handling, transporting, installation or use of such banners.
2. Banner User hereby releases the City of Ukiah from all liability, contractual or otherwise, and waives all claims against the Releases for but not limited to the following situations:
  - a. Mistakes made in installation of Banner User's banners;
  - b. Damage to Banner User's banners during storage, transport, installation, or use;
  - c. Theft of Banner User's banners;
  - d. Money lost due to scheduling conflicts which prevent City of Ukiah installation of Banner User's banners.
  - e. Installer errors in placement
3. Banner User agrees that this agreement is intended to be as broad and inclusive as is permitted by the law of the State of California and that if any portion thereof is held invalid it is agreed that the balance shall notwithstanding continue in full legal force and effect.

IN WITNESS WHEREOF, City of Ukiah and Banner user by their respective officers thereunto duly authorized, have executed this Downtown Banner use Agreement as of the above written date.

CITY OF UKIAH

"Banner User"

By: \_\_\_\_\_

By: \_\_\_\_\_

Title: \_\_\_\_\_

## Exhibit "D"

### BANNER TECHNICAL SPECIFICATIONS

#### Downtown Light Pole Banner Program

Banner Specifications listed below:

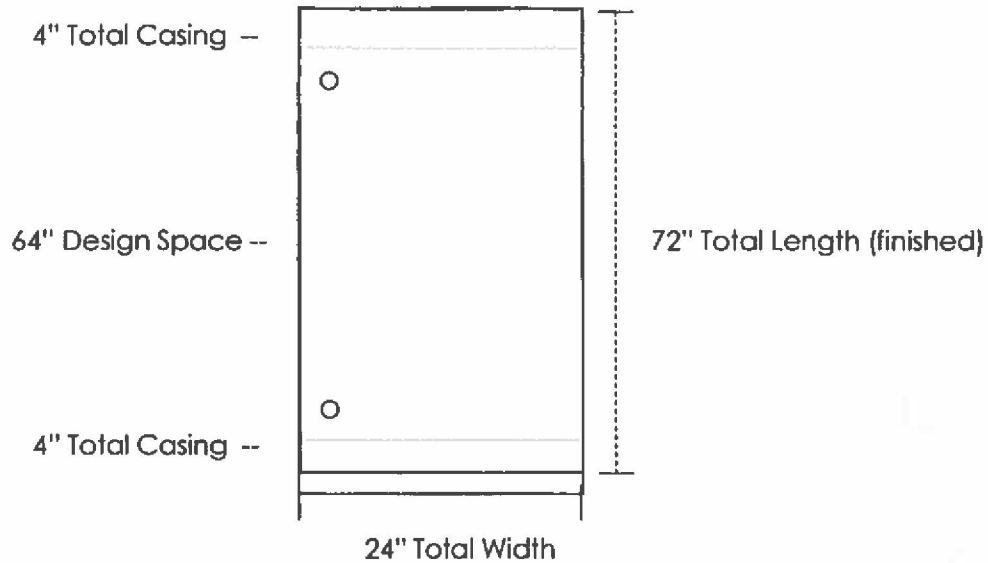

**Please Note:**

**Design should include bold solid design elements for maximum visibility.**

**Design should include highly contrasting colors for maximum visibility.**

**A grommet should be placed 1" below the top casing line, another 1" above the bottom casing line and both of these grommets should be 1" in from the edge.**

# Downtown Light Pole Banner Program Location Map

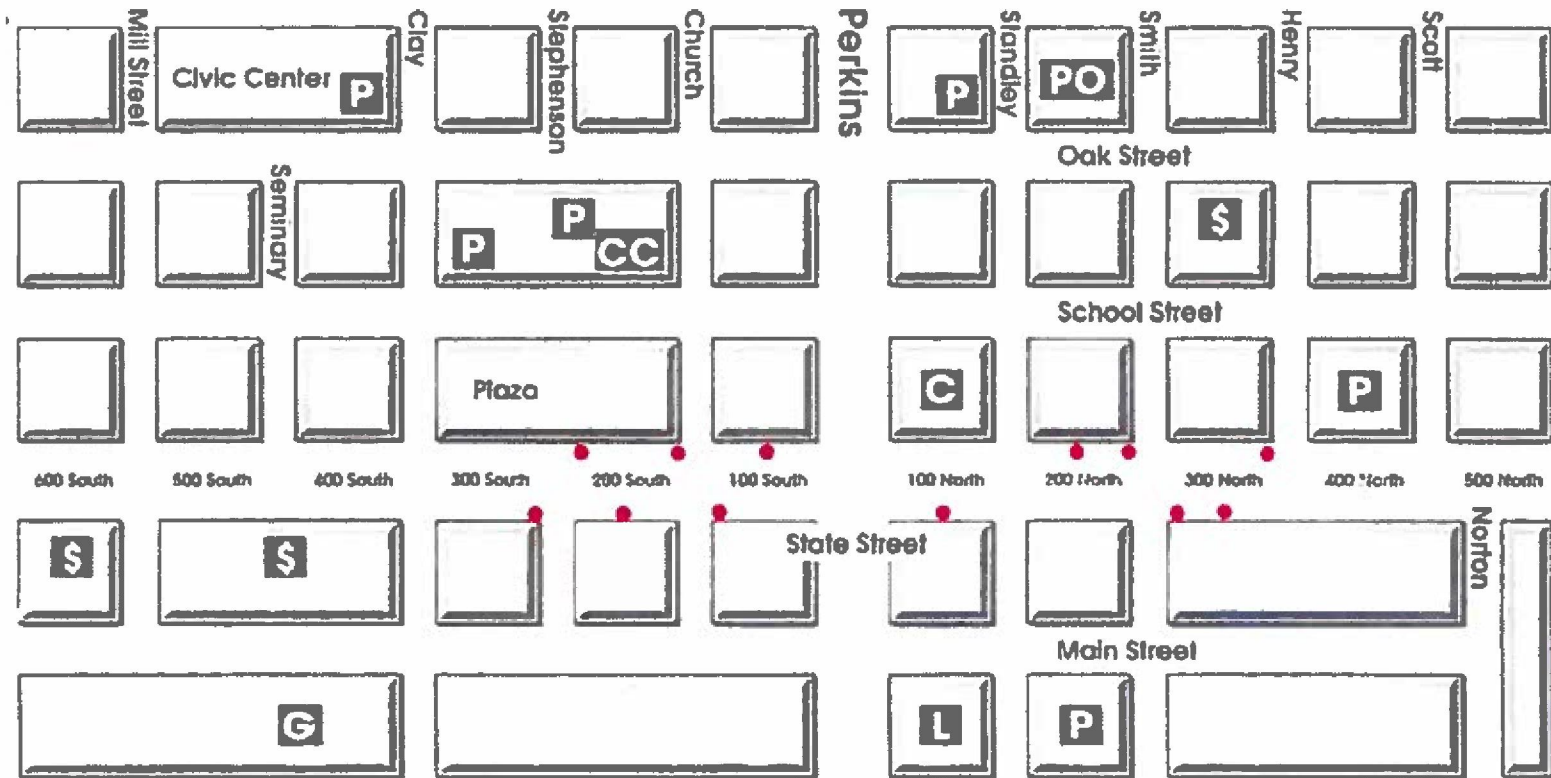

<b>P</b> Parking Locations	<b>S</b> ATM Machine	<b>L</b> Library	<b>PO</b> Post Office
<b>CC</b> Ukiah Valley Conference Center	<b>G</b> Grace Hudson Museum	<b>C</b> Court House	